

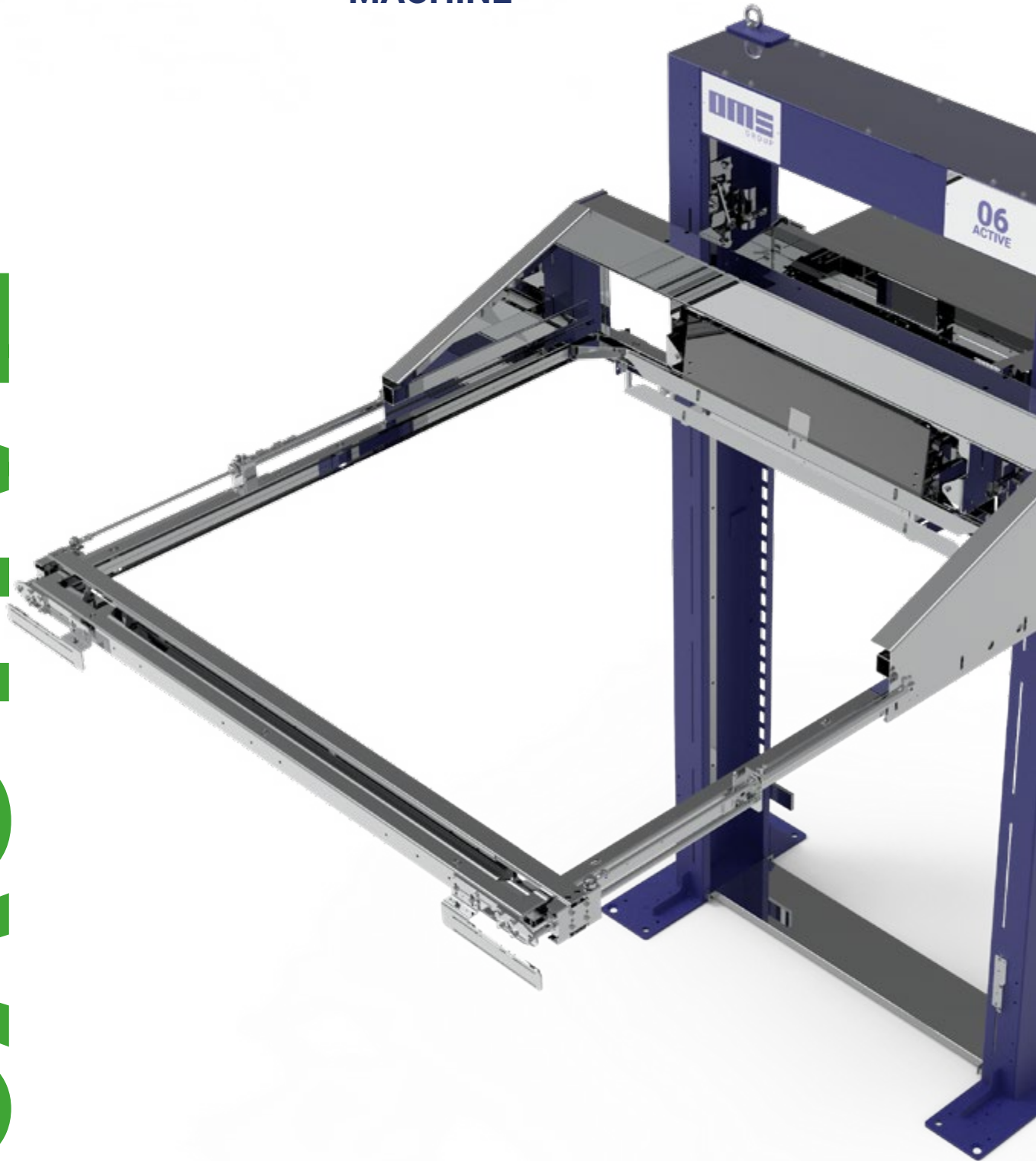

HORIZONTAL STRAPPING MACHINE



06ACTIVE

06ACTIVE



HORIZONTAL STRAPPING
MACHINE

SMART - FLEXIBLE - SIMPLE

The **06ACTIVE** is a **horizontal strapping machine** primarily designed for the **brick and concrete interlocking paver industry**. It is suitable for use with both palletized and non-palletized products on automated lines.

The **head movement** and opposite **strap guide** are **pneumatically operated**, while the arch's upward and downward motion is managed by a gearmotor controlling a belt system, **all driven by an inverter**



STRAPPING

WHY BUY

HIGH PERFORMANCE AND SPEED

QUICK AND EASY INSTALLATION

CONFIGURABLE MODULAR STRUCTURE

NOISILESS AND QUICK MOVEMENT

USER FRIENDLY & EASE OF MAINTENANCE

SAFE & DURABLE

LOWER CONSUMPTION



FEATURES

Pneumatic head movement
towards the package with probe
for stroke stop



Belt Drive

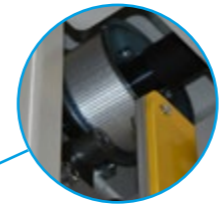

**Arch with steel structure and
aluminum strap passage, with
anti-collision safety photocells**
for descent movement

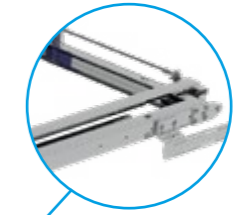

**Automatic descent
blocking device, in any position,**
for machine maintenance



**Standard coil holder
PB 11**



**Anti-collision safety
photocells** for descent
movement



**Machine control panel
with HMI**

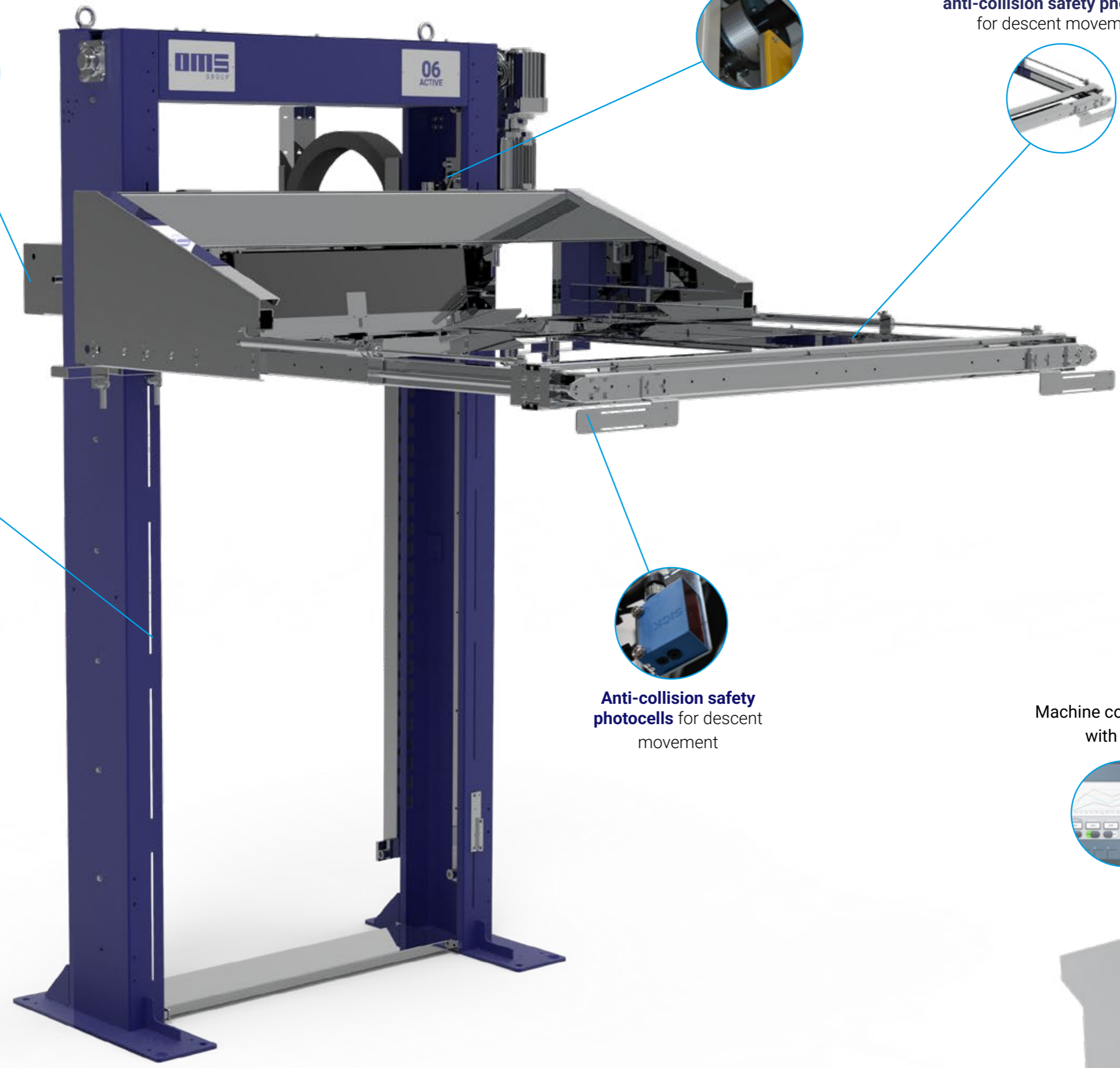

Other features

Strap guide advancement stroke up to 620mm



Strap end sensor on coil holder



Feeler plate for head stop on package

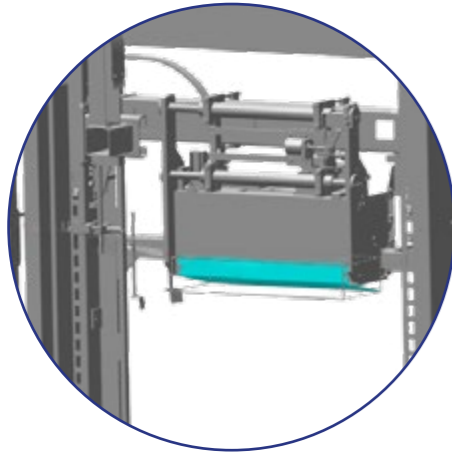

Optionals

- Automatic strapping re-feed

Applications



BRICKS



CONSTRUCTION



CERAMIC



LOGISTICS



GLASS



FRUITS and
VEGETABLES



BALES



OTHER SECTORS

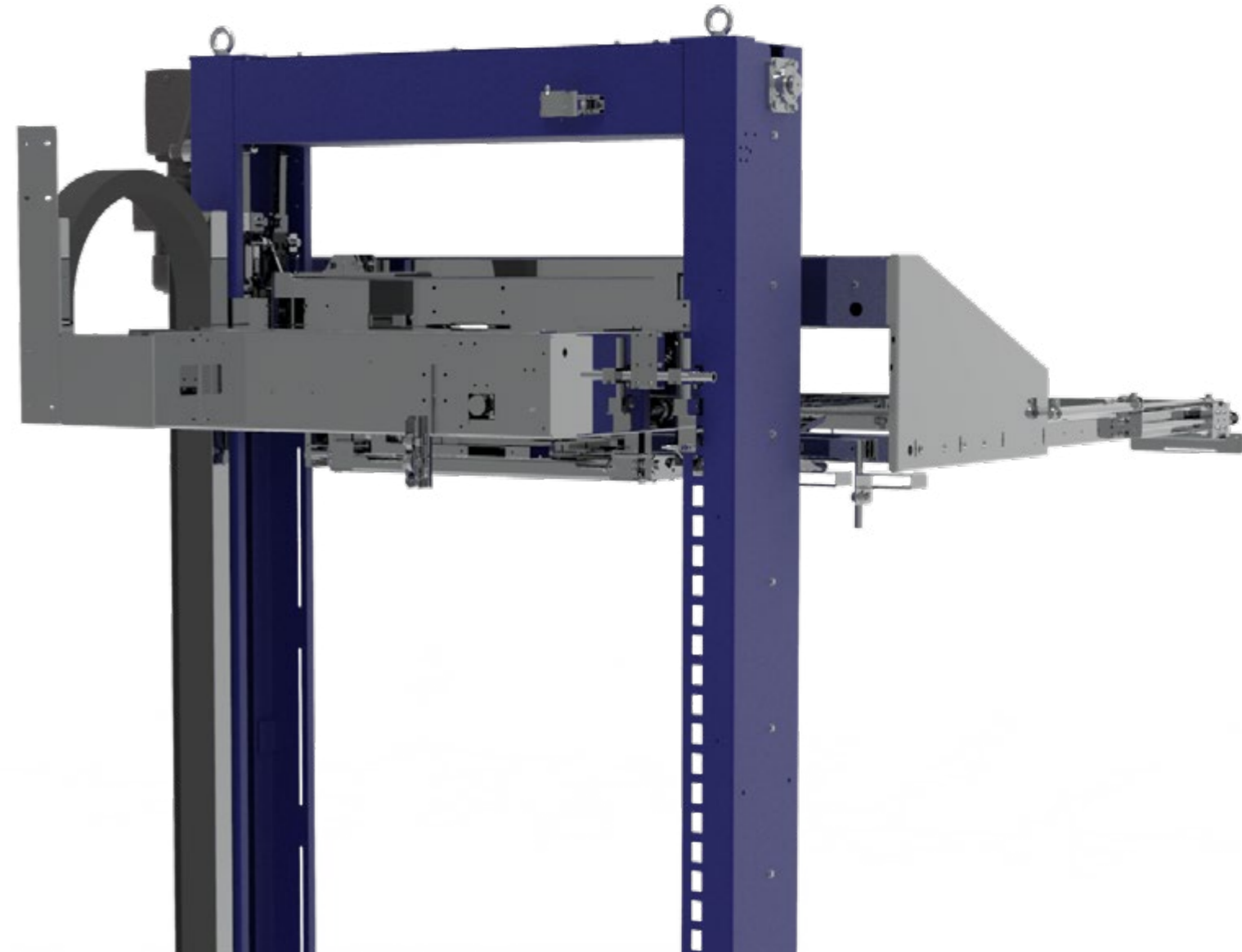

06ACTIVE



HORIZONTAL STRAPPING
MACHINE

SMART - FLEXIBLE - SIMPLE



www.oms-group.com
info@oms-group.com

