



AV1800 PREMIUM - AVR1000 -  
AV3000

WRAPPING



# AV1800 PREMIUM



ROTATING ARM

The **AV1800 PREMIUM** is a **rotating arm wrapping machine** supported by **fifth wheel**, primarily used in the **paper, cardboard, ceramics, fruit, bricks, wood, cans, logistics** and **glass industries**.

It can be used for palletized and non-palletized products on automatic lines. The machine is equipped with a **motorized pre-stretching group**, it also has the possibility to have a double motor for changing pre-stretching ratios thanks to its software. The welding cutting unit is pneumatically powered. Welding is by hot plugs, with hot wire cutting. The **AV1800 PREMIUM** is also available as **ACTIVE version**, without counterweight.



# AV1800 PREMIUM

# WHY BUY

SIMPLE

FULLY AUTOMATIC  
SYSTEM

OPTIMIZED DESIGN

CONFIGURABLE MODULAR  
STRUCTURE

USER FRIENDLY AND EASE  
OF MAINTENANCE

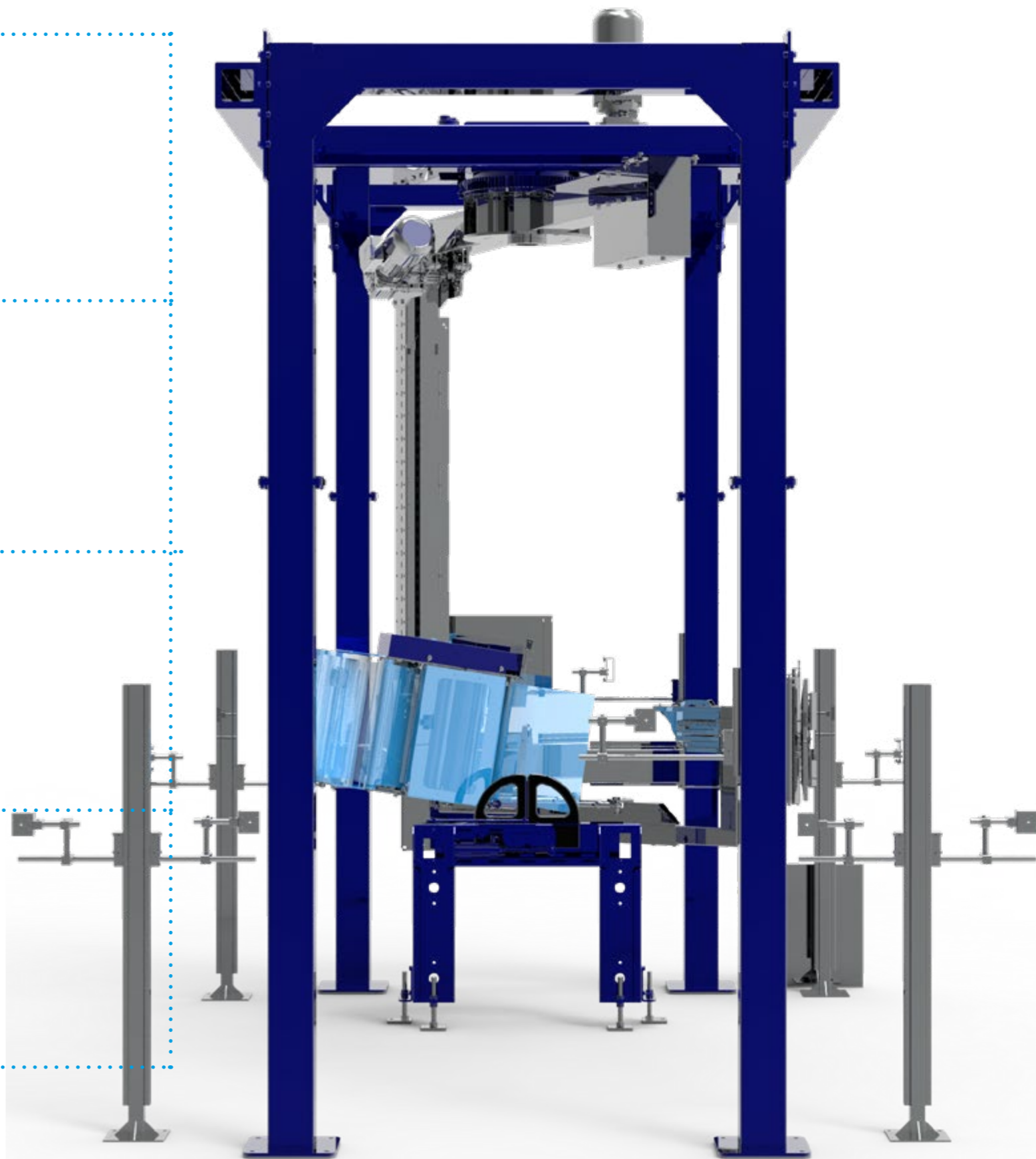

# FEATURES

Maximum arm rotation speed: 32 RPM

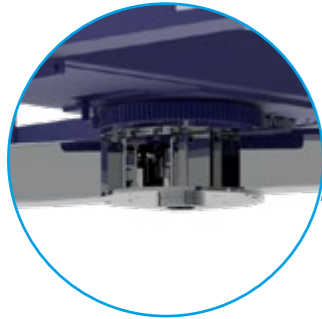

Motorized lifting prestretch by belt run by inverter



Motorized prestretch by fixed ratio, run by inverter (fixed prestretch pulleys set 200% - 250% - 300%)

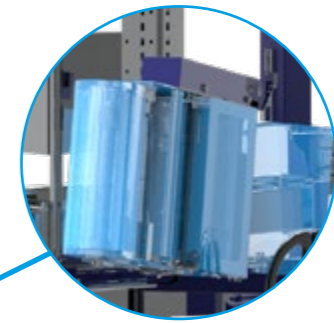

Film clamping group fixed on the conveyor or on a support to the floor



Modular structure



Pneumatic film cutting and welding device

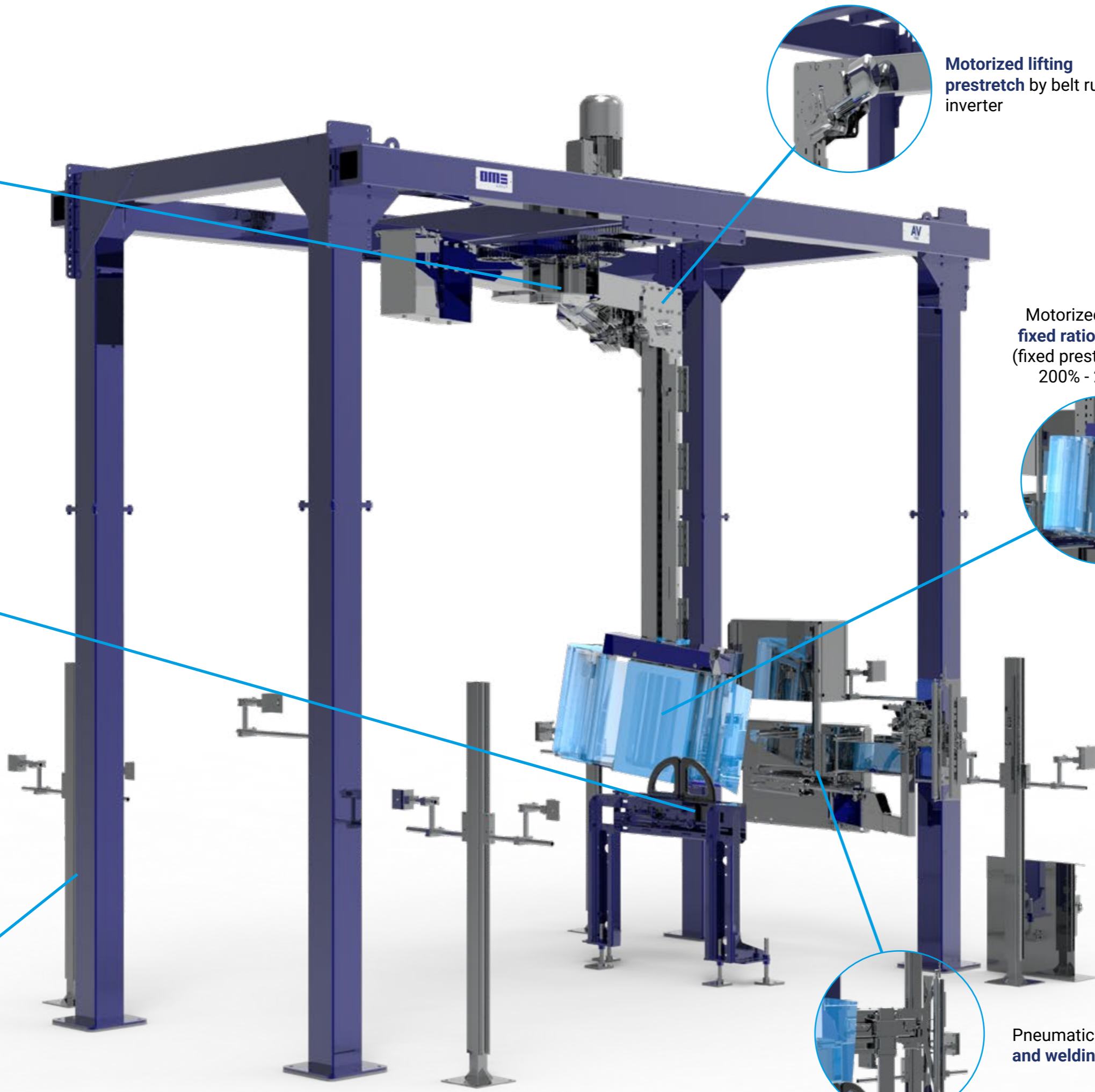

# Optionals

Pneumatic pantograph stabilizer press



Motorized band reduction device



Single-reel sheet feeder

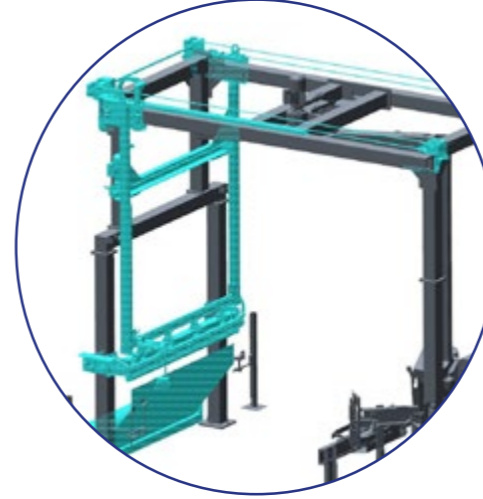

Double-reel sheet feeder



Motorized pre-stretch with 1 brushless motor, H=750 mm



Motorized pre-stretch with 2 brushless motors



Fixed welding backing plate



Movable welding backing plate



## Applications

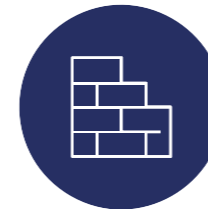

BRICKS



CONSTRUCTION

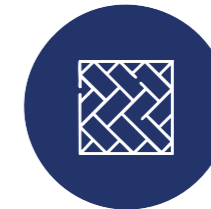

CERAMIC



WOOD



BAGS



BALES



HOLLOW GLASS



CANS



PAPER



FLAT and  
CORRUGATED



LOGISTICS

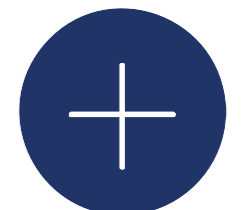

OTHER SECTORS

# AV1800 ACTIVE

Maximum arm  
rotation speed: 22 RPM

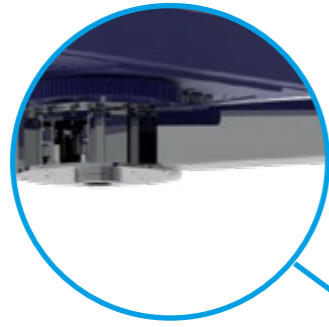

The AV1800 Active represents an **optimized version** with:

- **lower power motors**
- **compact PLC**
- **reduced rotation speeds**
- **no counterweight**, thanks to the reduction of moving masses and operating speeds

## AVR1000



ROTATING RING

The **AVR1000** is a **rotating ring wrapping machine** supported by **rubbered wheels**, primarily used in the **paper, cardboard, ceramics, fruit, bricks, wood, cans, logistics** and **glass industries**. It can be used for palletized and non-palletized products on automatic lines. The machine is equipped with a **motorised pre-stretch system**. The welding cutting unit is an incandescent lamp or node unit. The **AVR1000** can also be equipped with a **small press, top sheet dispenser** and **adaptor band**.



# AVR1000

# WHY BUY

HIGH SPEED PERFORMANCE

REDUCED SAFETY AREA

OPTIMIZED DESIGN

FULLY AUTOMATIC SYSTEM

QUICK AND EASY  
INSTALLATION



# FEATURES

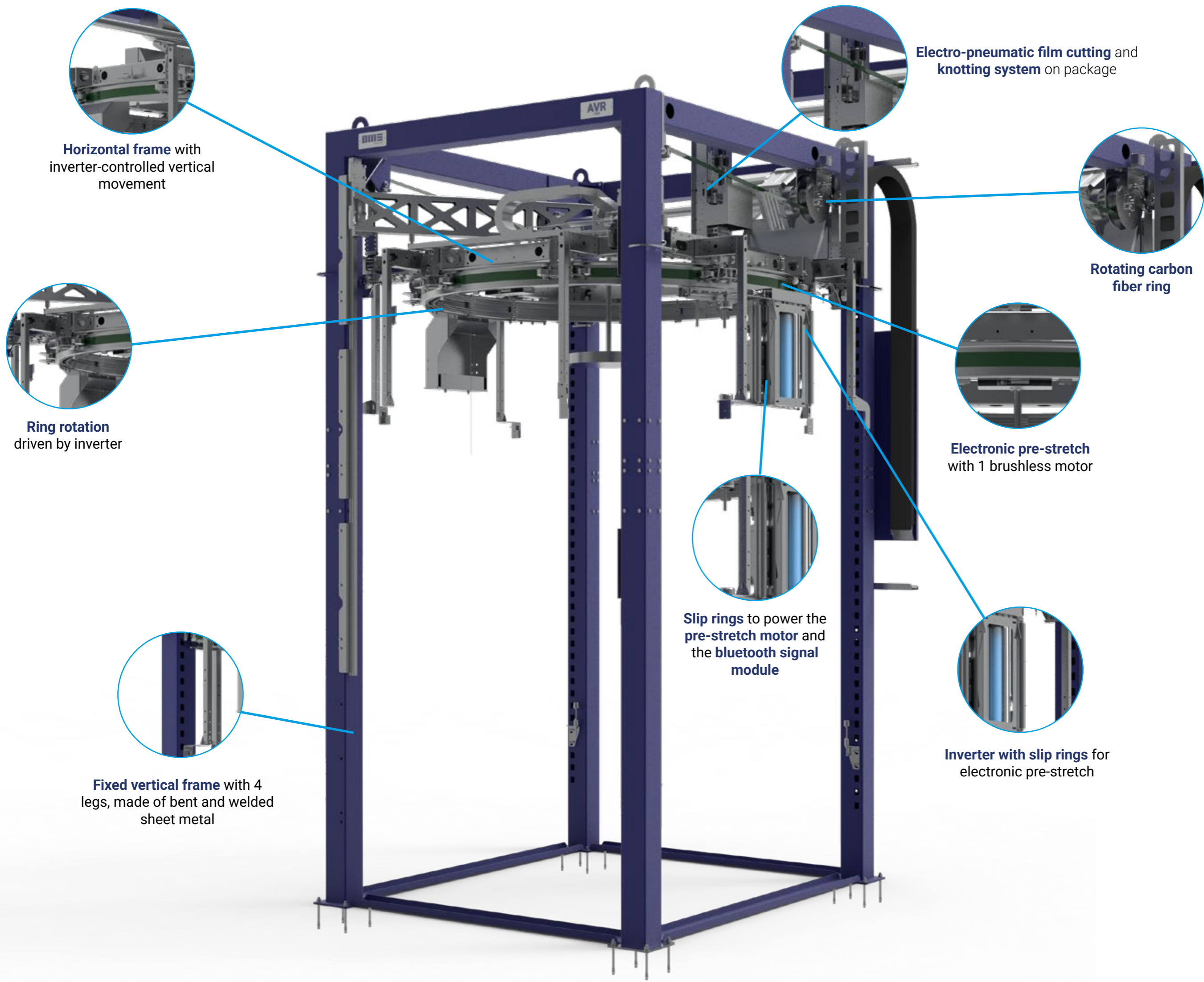

**Horizontal frame** with inverter-controlled vertical movement

**Electro-pneumatic film cutting** and knotting system on package

**Rotating carbon fiber ring**

**Ring rotation** driven by inverter

**Electronic pre-stretch** with 1 brushless motor

**Slip rings** to power the pre-stretch motor and the bluetooth signal module

**Inverter with slip rings** for electronic pre-stretch

**Fixed vertical frame** with 4 legs, made of bent and welded sheet metal

# Optionals

Gravity stabilizer press



Gravity stabilizer press + cylinder for feeder passage



Automatic coil change

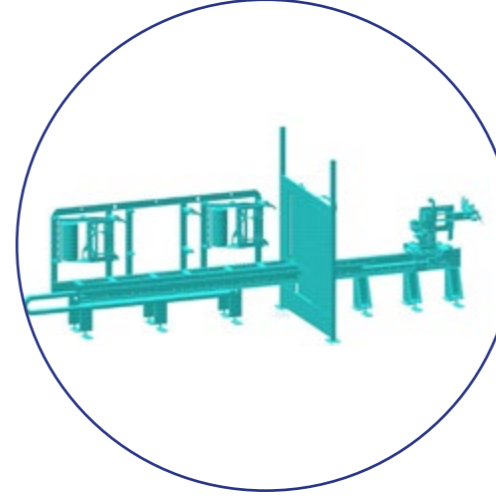

Single band lowerer

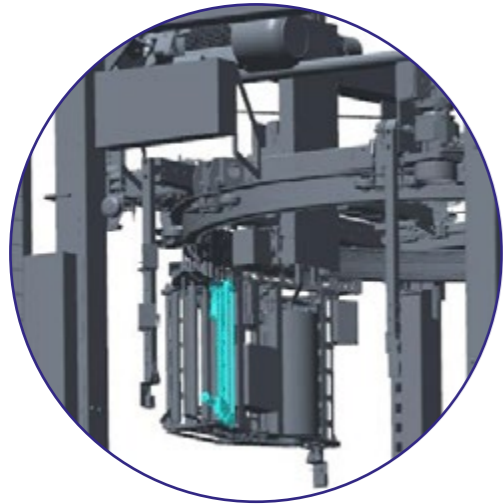

Double twin band lowerer

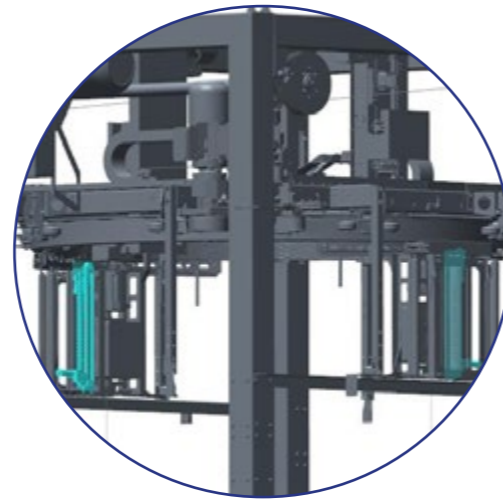

Package lifter with stroke up to 100 mm

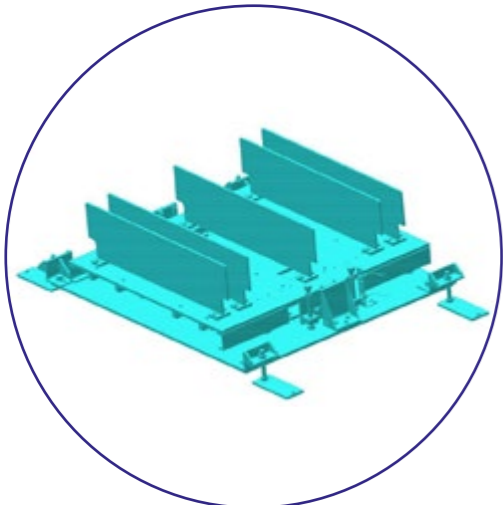

Second coil for printed film

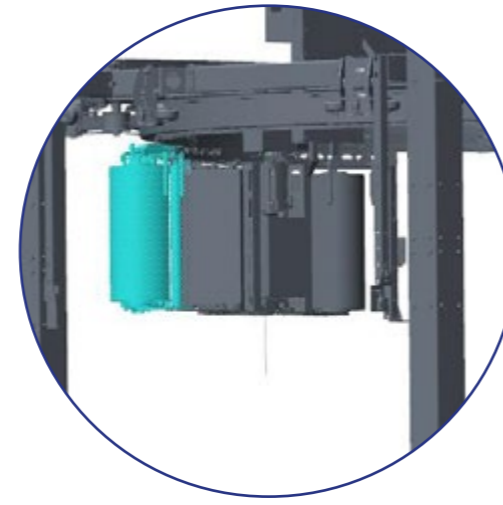

# Applications

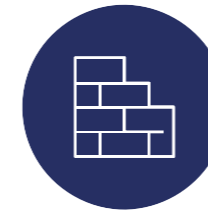

BRICKS



CONSTRUCTION



CERAMIC



WOOD



BAGS



BALES



HOLLOW GLASS



CANS



PAPER



FLAT and  
CORRUGATED



LOGISTICS

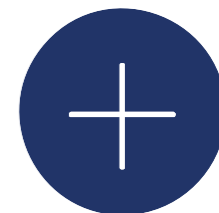

OTHER SECTORS

## AV3000



ROTATING TABLE

The **AV3000** is a **turntable wrapping machine** with **roller** or **5/3 strand chain conveyor** primarily used in the **paperboard, bags, and ceramic industries**.

It can be used for palletized and non-palletized products on automatic lines.

The machine is equipped with a **turntable on fifth wheel** and **motorised pre-stretching system**: this movement is vertical and the cut/welding unit is pneumatically powered.

Welding is by hot plugs, with hot wire cut.

The **AV3000** can also be supplied with a **small press, top sheet dispenser** and **band adaptor**.



# AV3000

# WHY BUY

**COMPACT**  
(machine+conveyors)

**STRONG STRUCTURE**

**OPTIMIZED DESIGN**

**VERSATILITY**

**USER FRIENDLY AND EASE  
OF MAINTENANCE**

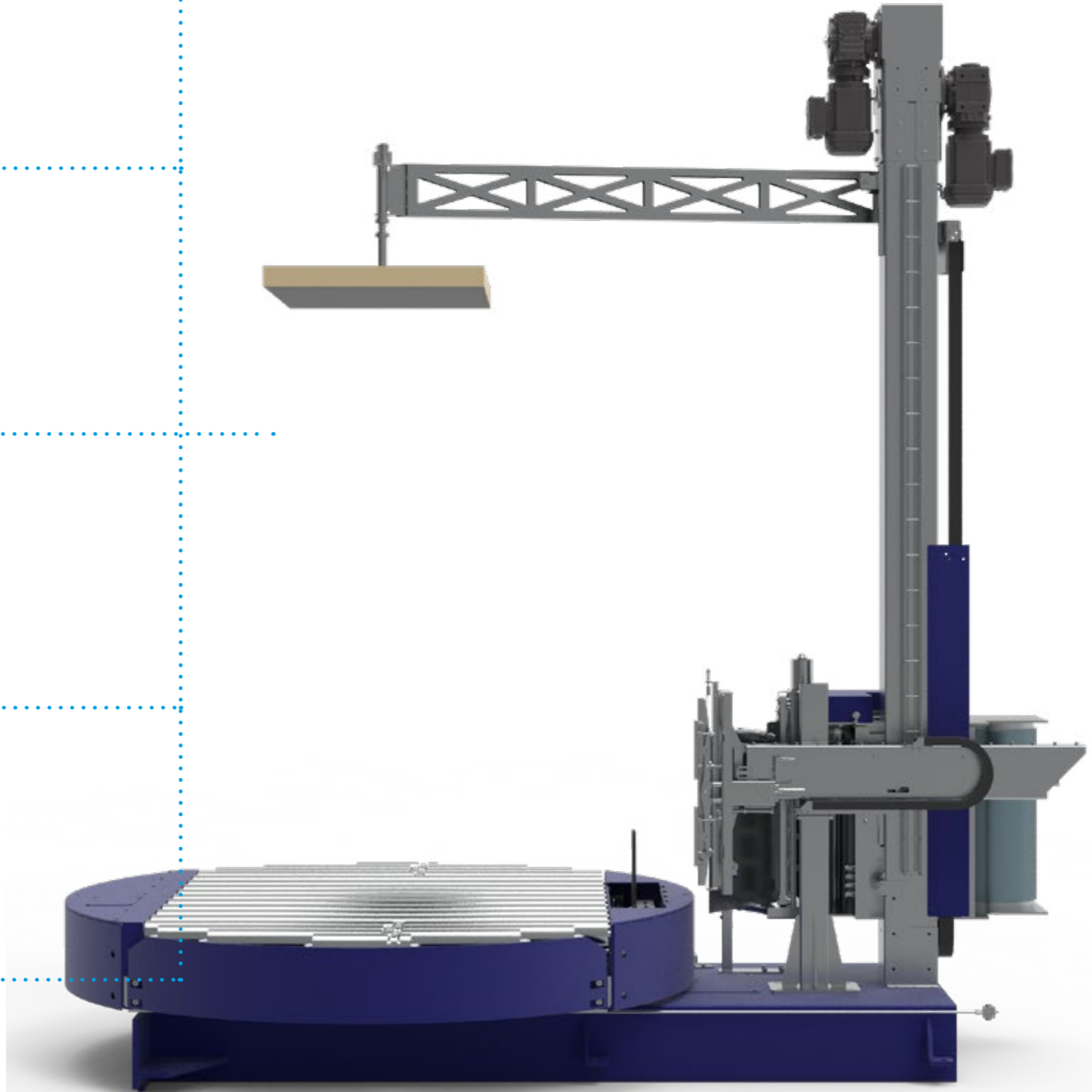

# FEATURES

**Single-column vertical frame**  
for pre-stretch lifting, inverter-driven

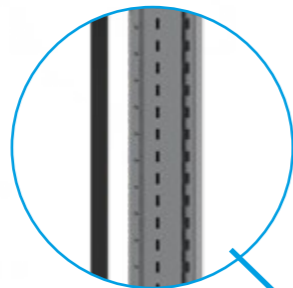

**Motorized film pre-stretch** with 1  
motor, for 500 mm reels



**Film cutting and sealing unit** moun-  
ted on the machine base



**Film clamping unit**  
on turntable

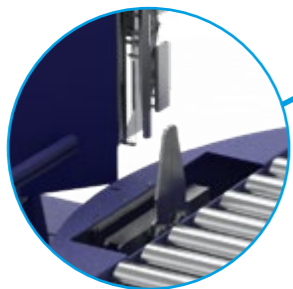

**Turntable** with motorized rollers  
or chains, mounted on the  
base frame

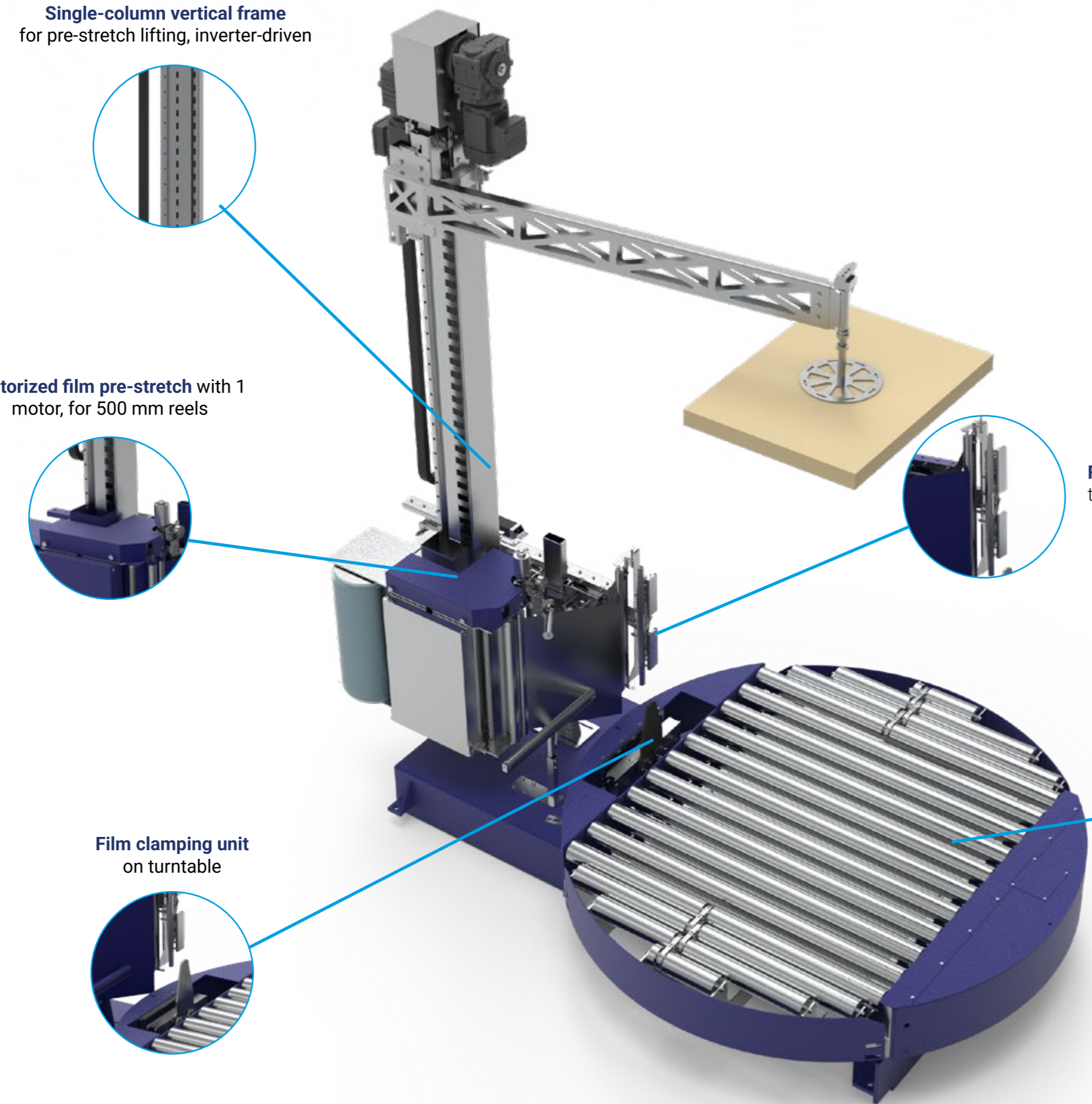
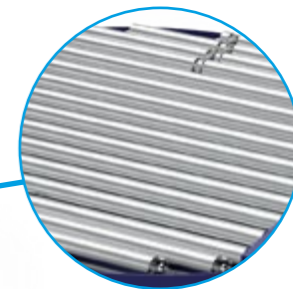

## Optionals

Motorized stabilizing press  
integrated into the machine column

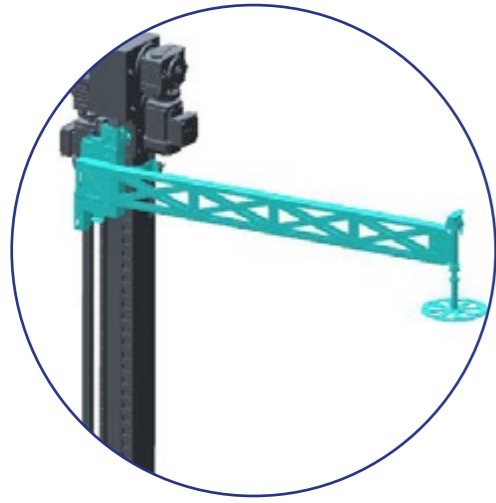

Sensors on turntable for 90°  
discharge



Electric band-lowering device

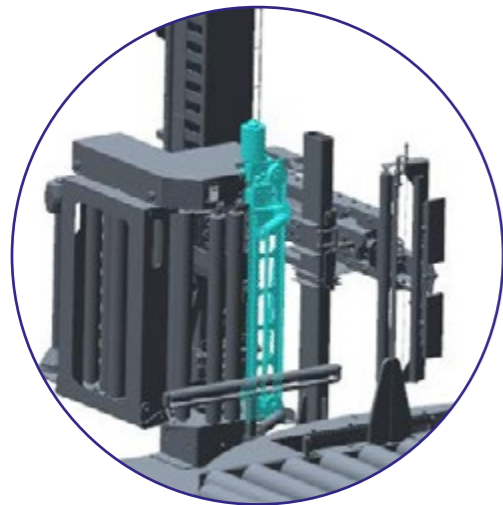

Movable welding backing plate

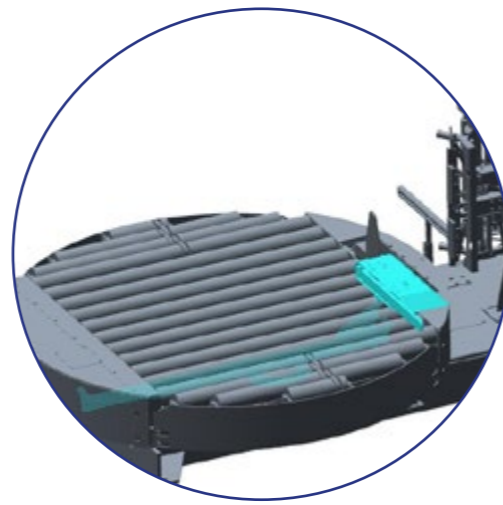

AV1800 PREMIUM -  
AVR1000 - AV3000



## Applications



BAGS



FLAT and  
CORRUGATED



LOGISTICS



OTHER SECTORS

ROTATING ARM - RING - TABLE



[www.oms-group.com](http://www.oms-group.com)  
[info@oms-group.com](mailto:info@oms-group.com)

